

Standard Probes & Assemblies

INDUSTRIAL GRADE TEMPERATURE SENSOR TYPE TS & TX

Features:

- Rugged, sealed stainless steel design
- Fully encapsulated sensing element
- Industry standard connectors and cordsets
- Accommodates a wide variety of sensing elements including thermistors, RTD's, IC sensors and silicon PTC's
- Wide operating temperature range: -40°C to 105°C

Options:

- Probe lengths, hex sizes
- Other thermistor values, curves and accuracies
- Other sensing elements

Description:

ATP types TS and TX are ruggedized probes that seal the sensing element from the outside environment. Because they include industry standard cordsets and connectors they are extremely easy to use. The sealed end design adds an extra level of moisture resistance over previous designs. These products simplify the installation and connection of temperature sensors in the harshest applications where the protection of the sensing element from the environment is critical. With this new design, it is now possible to have a fully enclosed sensor that will provide a lifetime of accurate and reliable sensing. Please contact the factory for specific design or application information or the availability of options.



Industrial Grade Temperature Sensors

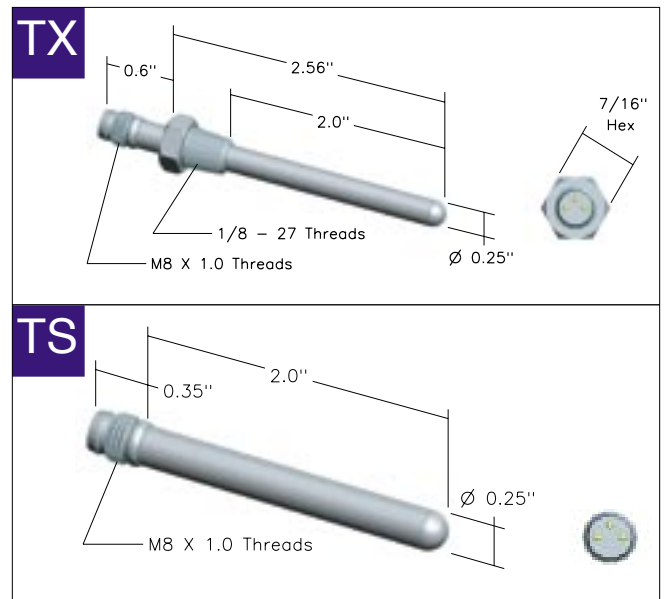

Ordering Information

SENSOR INFORMATION					CABLES WITH MOLDED CONNECTOR	
ATP Part Number*	R ₂₅ (Ω)	Sensor Type	Material Curve	Accuracy		
A2253T_43N1	2,252	NTC Thermistor	Z	±0.2°C, 0°C to 70°C	Straight	JCS24T0-2
A5003T_43N1	5,000	NTC Thermistor	Z	±0.2°C, 0°C to 70°C	Right Angle	JCR24T0-2
A1004T_43N1	10,000	NTC Thermistor	Z	±0.2°C, 0°C to 70°C	Standard cable length is 2 meters. Cable material is polyurethane jacket. Cable and sensors are sold separately.	
S1003T_43N1	1,000	Silicon PTC	SIL	±1.5°C at 25°C		
RP102T_43N1	100Ω @ 0°C	Pt PRTD	DIN385	±0.3°C at 0°C		

*Replace T_ with either TS or TX for desired housing style.

Resistance versus temperature data for material curve can be found on page 57 and for Pt RTD can be found on page 68.