

Features:

- Provides a standard 4-20mA signal output
- Linear output with respect to temperature
- Push button calibration
- Cost efficient design
- Sturdy construction
- Highly accurate response
- Suitable for in head or DIN rail mounting

Description:

The ATP push button transmitter connects to a standard 10k Ω thermistor or 100 Ω Pt RTD sensor and produces a 4-20mA signal that is linear with temperature. The transmitter can be mounted on a DIN Rail or in a junction box for attaching directly to the temperature sensor or for surface mounting to a wall or duct. A digital indicator can also be incorporated.

The simple push of a button ranges and calibrates the PBT420 transmitter. There is no need for jumpers or pot adjustments. The high accuracy, stability, flexibility and low cost of the PBT420 make it ideal to use in those applications where a 4-20mA output is desirable.

To calibrate the PBT420, connect a thermistor simulator or resistance decade box to the input and a voltage between 8 and 30 VDC to the PBT420. Set the simulator or decade box to the resistance value corresponding to the desired temperature for an output of 4mA. Press and hold the calibration button down until the LED starts to blink and then release. Set the simulator or decade box to the resistance value corresponding to the desired temperature for an output of 20mA. Press the calibration button and release. The LED continues blinking and then shuts off confirming that the transmitter is calibrated.

A complete data sheet with input and output specifications is available by contacting ATP Engineering.



Push Button Temperature Transmitter

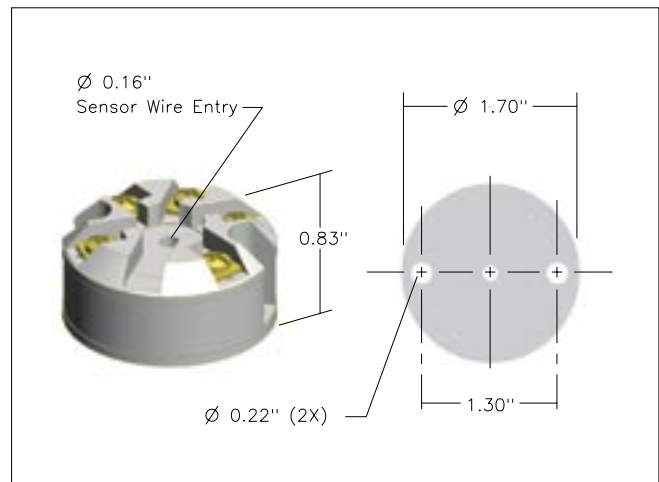

Ordering Information

ATP Part Number	R ₂₅ (Ω)	Material Curve
PBT420-10KT	10,000	Z
PBT420-100R	100	Pt RTD

Resistance versus temperature data for material curve can be found on page 57 and for Pt RTD can be found on page 68.